



Manufacturers of the
Ultimate sawmill
from New Zealand



INNOVATIVE

Sawmills



- High production <
- Strong construction <
- Patented sawmill design <
- Simple and ergonomic to use <
- Fast, safe, efficient, and accurate <
- Adapts to any log diameter - blocks to prop <
- Replacable carbide insert teeth with extra locking <
- Saw the log as it lays on the ground, no need to rotate <

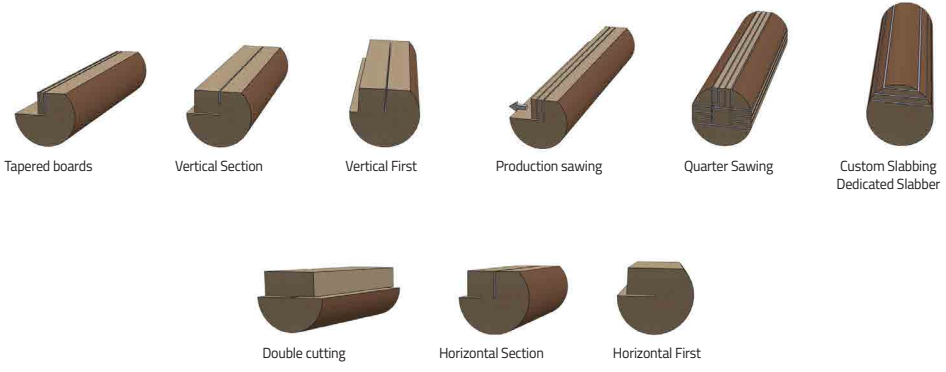

Any questions? Need information?

Contact us : +64 7 578 9771 - jake@turbosawmill.co.nz



- **DED:** Mobile dedicated slabber mill.
CUSTOM - suited for wide live edge table tops.

Cut wide live edge slabs up to 1.5m (5ft) with our cutting-edge solution featuring a Honda 13HP electric start gasoline engine.

Cutting length of 4.2m (14ft). Extendable to 6.2m (20ft) optional

- Double end oiler.
- Crank winch for easy feed.
- Centrifugal clutch for easy starting.
- Oscillating bar for efficient cutting.
- Easy 180° access for board removal and log loading.
- Easy belt and chain tensioning system.
- Easy alignment adjustment of the bars.
- Honda 13 HP engine.

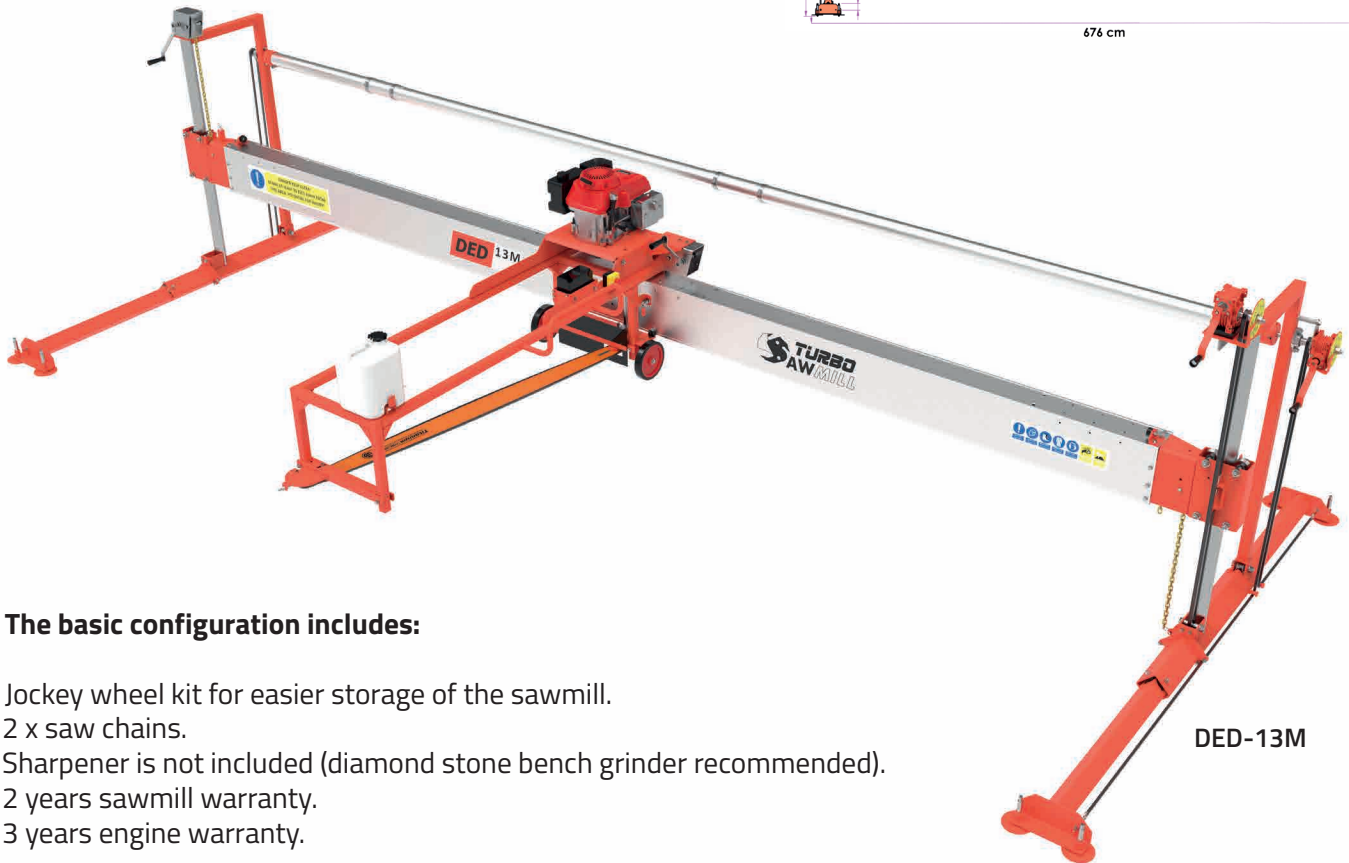
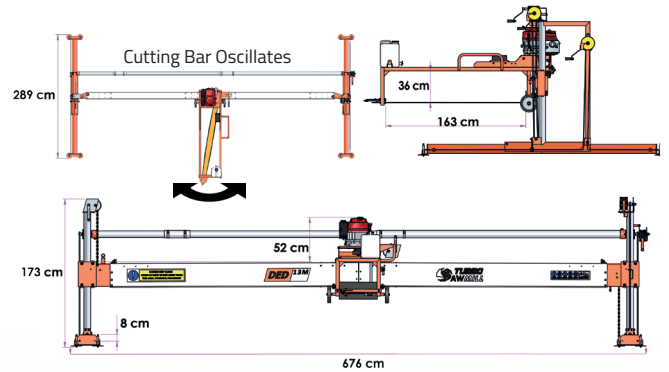

The basic configuration includes:

- Jockey wheel kit for easier storage of the sawmill.
- 2 x saw chains.
- Sharpener is not included (diamond stone bench grinder recommended).
- 2 years sawmill warranty.
- 3 years engine warranty.

DED-13M

MODELS	Slabber with bar and chain DED-13M
Power	 Motor HONDA 13 HP
Working length (m)	6.76 (22ft)
Working width (m)	2.89 (9.5ft)
Working height (m)	1.73 (5.6ft)
Weight (kg)	396 (873lb)

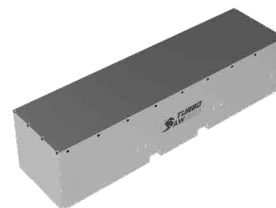

Cubic volume: 1.6 (91ft).
1 x crate. 575kg (1267lb).

■ **M6 Warrior:** Ultra-lightweight mobile sawmill.

LIFE STYLER - For the land owner, lower cost and designed to be pushed through the log.

The Warrior range offers an incredibly lightweight sawmill that is designed for ultimate portability. Two people can easily carry the saw into tight spots and set it up around the log. The mill features dual carry handles and a frame that splits into smaller, more manageable pieces. This model is perfect for those who need a portable and efficient milling solution.

For logs preferably of 1.2m (4ft) diameter although all diameters can be cut.
Cutting length of 4.2m (14ft). Extendable to 6.2m (20ft) optionally.

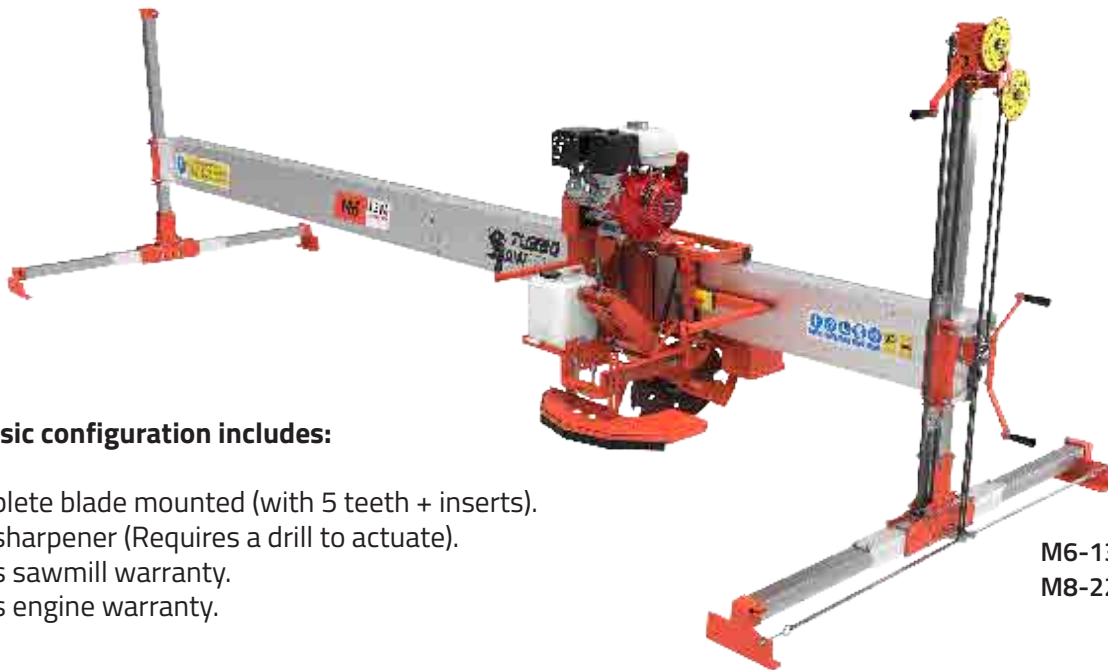
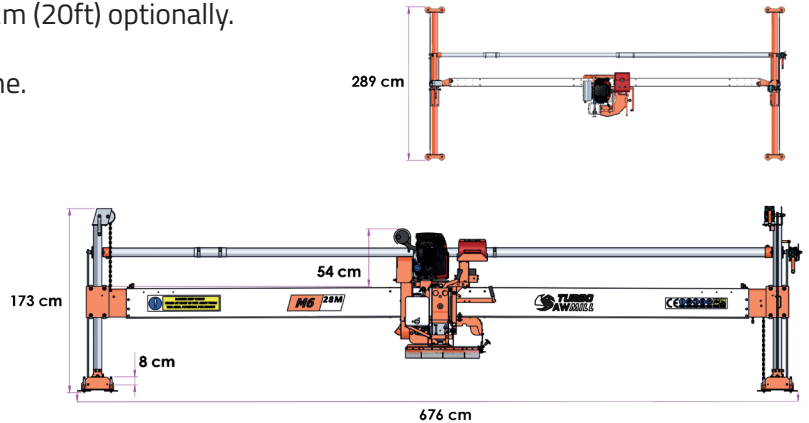

- Double cut possible. No need to rotate the frame.
- One run produces an edged board.
- Manual feed.
- Electric or pull start.
- Easily replaceable 5-tooth blade.
- Single end horizontal and vertical sizing.
- Easy to operate and maintain.



M6-13M Warrior
M8-22M Warrior

The basic configuration includes:

- 1 complete blade mounted (with 5 teeth + inserts).
- Tooth sharpener (Requires a drill to actuate).
- 2 years sawmill warranty.
- 3 years engine warranty.

MODELS	Mobile sawmill manual model	Mobile sawmill manual model
	M6-13M Warrior	M8-22M Warrior
Power	 Motor Honda 13 HP	 Motor Honda 28 HP
Working length (m)	6.76 (22ft)	6.76 (22ft)
Working width (m)	2.89 (9.5ft)	2.89 (9.5ft)
Working height (m)	1.73 (5.6ft)	1.73 (5.6ft)
Weight (kg)	280 (617lb)	310 (680lb)



Cubic volume: 0.78 (27ft).
2 x crates. 310kg (680lb).

■ **M10:** Mobile sawmill with manual feed.

LIFESTYLER - For the land owner, extra versatile and designed to be pushed through the log.

Introducing the manual cutting solution with extra depth capability: a powerful and versatile model equipped with a robust 28HP Honda gasoline engine. This high-performance tool is designed to meet your toughest cutting needs, offering efficiency and reliability in every job. It cuts boards up to 250mm x 250mm (10 inches) and can double cut up to 225mm x 500mm (20 inches), ensuring you get the precise results you need every time.

For logs preferably of 1.2m (4ft) diameter although all diameters can be cut. Cutting length of 4.2m (14ft). Extendable to 6.2m (20ft) optionally.

Double cut possible. No need to rotate the frame.
 One run produces an edged board.
 Manual feed.
 Electric start.
 Easily replaceable 5-tooth blade.
 Single end horizontal and vertical sizing.
 Easy to operate and maintain.

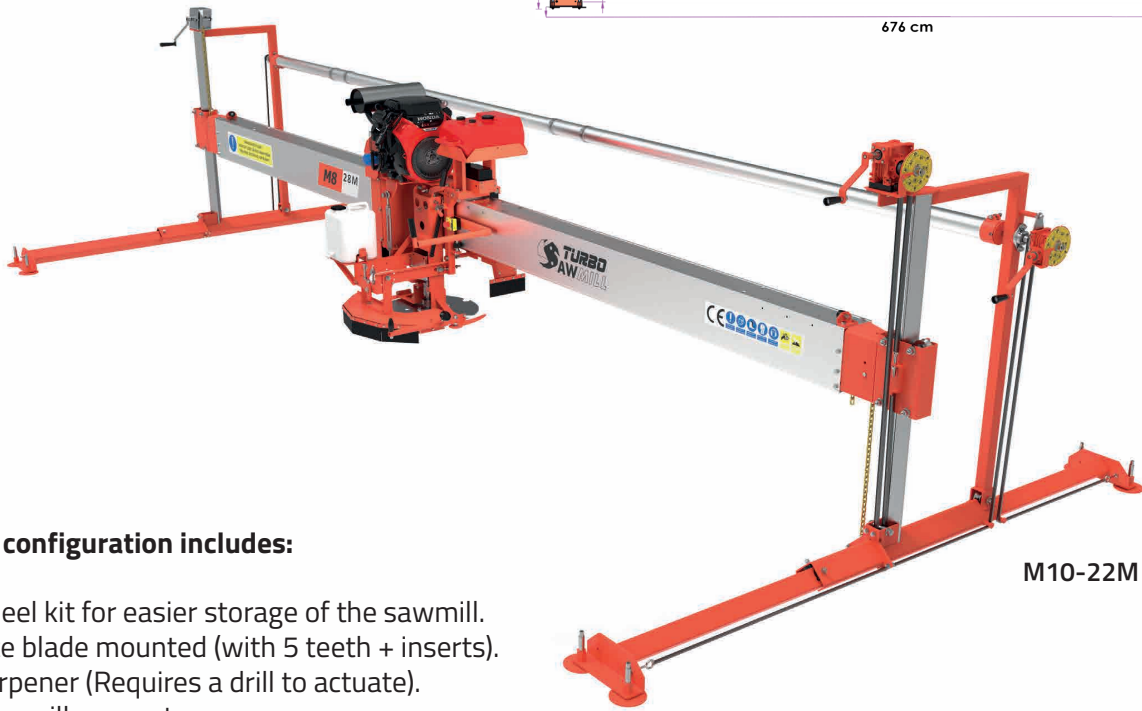
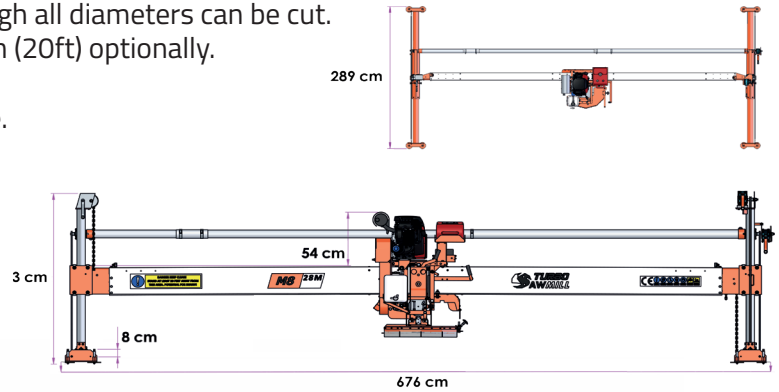

M10-22M

The basic configuration includes:

- Jockey wheel kit for easier storage of the sawmill.
- 1 complete blade mounted (with 5 teeth + inserts).
- Tooth sharpener (Requires a drill to actuate).
- 2 years sawmill warranty.
- 3 years engine warranty.

MODELS	Mobile sawmill manual model	Mobile sawmill manual model
	M10-22M	M10-15M
Power	Motor Honda 28 HP	Motor Electric 15 HP
Working length (m)	6.76 (22ft)	6.76 (22ft)
Working width (m)	2.89 (9.5ft)	2.89 (9.5ft)
Working height (m)	1.73 (5.6ft)	1.73 (5.6ft)
Weight (kg)	450 (992lb)	480 (1058lb)



Cubic volume: 2.8 (98ft).
 2 x crates. 640kg (1410lb).

■ **M12:** Mobile sawmill with automated feed.

PROFESSIONAL - For production sawmilling, powered through the cut with a lever.

Introducing the automated cutting solution: a powerful and versatile model equipped with a robust 30HP Honda gasoline engine. This high-performance tool is designed to meet your toughest cutting needs, offering efficiency and reliability in every job. It cuts boards up to 300mm x 300mm (12 inches) and can double cut up to 275mm x 600mm (24 inches), ensuring you get the precise results you need every time.

For logs preferably of 1.2m (4ft) diameter although all diameters can be cut.
Cutting length of 6m (20ft). Extendable to 8m (26ft) optionally.

Double cut possible. No need to rotate the frame.

One run produces an edged board.

Automatic feed.

Electric start.

Easily replaceable 5-tooth blade.

Single end horizontal and vertical sizing.

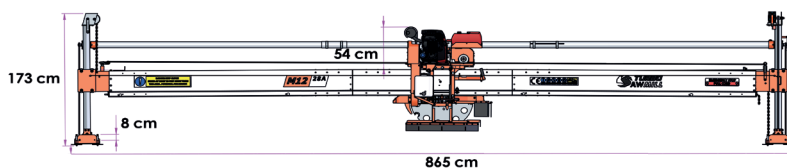
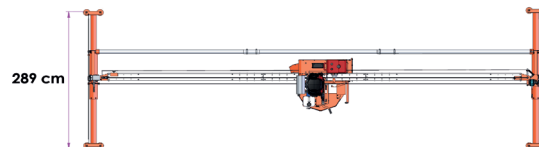

Easy to operate and maintain.



M12-28A

The basic configuration includes:

- Jockey wheel kit for easier storage of the sawmill.
- 1 complete blade mounted (with 5 teeth + inserts).
- Tooth sharpener (Requires a screwdriver).
- 2 years sawmill warranty.
- 3 years engine warranty.

MODELS	Mobile sawmill automatic feed	
	M12-28A	M12-25A
Power	 Motor Honda 30 HP	 Motor Electric 25 HP
Working length (m)	8.65 (28ft)	8.65 (28ft)
Working width (m)	2.89 (9.5ft)	2.89 (9.5ft)
Working height (m)	1.73 (5.6ft)	1.73 (5.6ft)
Weight (kg)	660 (1455lb)	690 (1521lb)

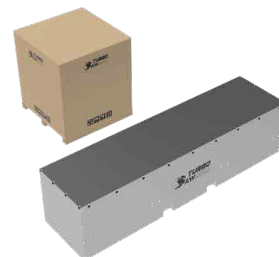

Cubic volume: 2.8 (98ft).
2 x crates. 935kg (2060lb).



■ **Mobility kit**

Includes a cart and holding clamps to connect to your sawmill for easier transportation.

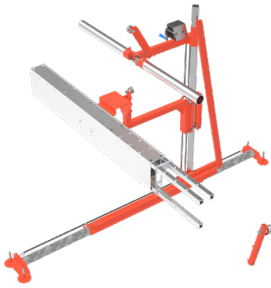

Extension with leg

■ **Extension of 2m (6ft) or 3m (9ft) in manual or automatic version**

Allows extending the length.

Middle leg only available on the M10 and M12 models.



■ **Digital sizing**

Allows upgrading the manual sizing to auto sizing.

Adaptable on the M10 and M12 models.

Consumables



Complete replacement kit: 1 blade + 5 inserts + 5 carbide teeth

For M6 saw - Ref.
For M8 saw - Ref.
For M10 saw - Ref.
For M12 saw - Ref.



Planing blade for optimal surface finish of beams and slabs

Ref



Replacement carbide insert: set of 5

Ref



Replacement carbide insert for planing blade

Ref



Replacement insert for holding carbide inserts in the blade

Ref

**MANUFACTURED
IN NEW ZEALAND**



TURBOSAWMILL LTD.

**62 Taniwha Place, Bethlehem, Tauranga
New Zealand. ZIP 3176**

Ph: +64 7 578 9771 (Workshop)

Office: +64 7 544 6132 (sales)

Email: jake@turbosawmill.co.nz

More international dealer details: www.turbosawmill.com

USA

Phone: **1-833-961-1904** Email: jake@turbosawmill.co.nz

CANADA

Phone: **780-853-3699** Email: office@swiftfoxindustries.ca

AUSTRALIA

Phone: **04 182 00001** Email: David@turbosawmill.com.au

EUROPE

Phone: **+33 (0)3 88 58 69 69** Email: guillaume.kaiser@a-m-r.fr



Any questions? Need information?

Contact us : +64 7 578 9771 - jake@turbosawmill.co.nz

www.turbosawmill.com

FOLLOW US

